

Signs and Sign Structures in the M.D.

Signs and sign structures are allowed on private property within the Municipal District of Bonnyville, but most require a development permit prior to placement. This info sheet will layout the steps required for a sign permit.

1. Are you near a Provincial Highway? Alberta Transportation requires a permit for all developments, including signs, within 300 metres (984 feet) from the provincial right-of-way or 800 metres (2,625 feet) from the centerline of a highway and public road intersection. <http://www.transportation.alberta.ca/2626.htm>

What if this is on private property do I still need approval from the province? Yes, Alberta Transportation needs to ensure that what is going up along the highways will not cause hazards or confusion for traffic, for example, an advertisement sign that displays traffic signs or flashing, or intermittent, or rotating lights.

If your sign requires Alberta Transportation approval as outlined above, we request that you proceed with getting that approval prior to applying for a permit from the M.D. A denial from Alberta Transportation would invalidate any permit issued from the M.D.

2. Is the sign located at your permitted business? You can have one freestanding sign on the property advertising the business. Additional signs shall require a permit. All other signs adjacent to M.D. roads or that have received Alberta Transportation approval require a Development Permit from the M.D. of Bonnyville.*

Complete applications will include:

- Completed Development Application
- Authorization form if required
- Site plan – show distances from property boundaries
- Sketch of proposed sign including dimensions of sign, height off ground and illustration of sign face

Setbacks

No sign of any kind shall be permitted in road allowances or within 1.5 metres (5 feet) of the boundary of the right-of-way of a municipal road.*

Corner Lot Restrictions: No development over 1 metre (3.3 feet) above grade shall be permitted in a corner visibility triangle on an intersection as illustrated below:

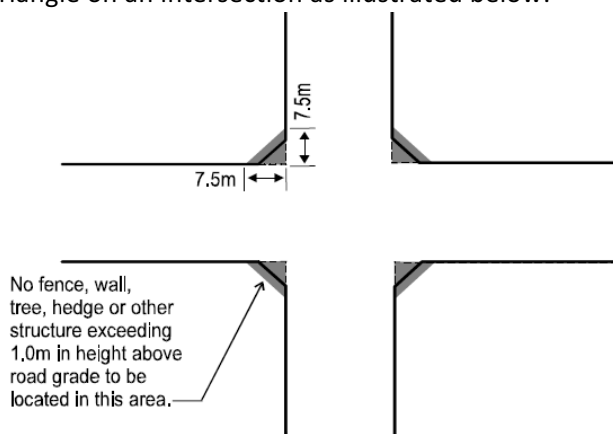

Figure 1 - Corner Visibility Triangle - Hamlet Districts

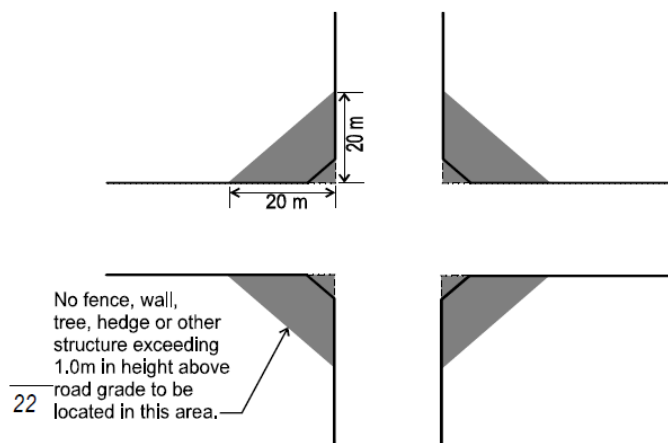

Figure 2 –Corner visibility triangle-Agricultural and Country Residential Districts

*Some exceptions apply, please contact the M.D. for more information

Please note this is a guideline and is for informational purposes only. It does not cover all of the rules, regulations or conditions that may be part of your sign approval.